

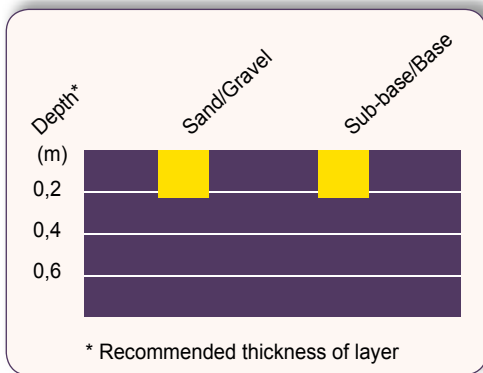

Versatile forward plate compactor high performance

Premium asphalt plates feature a durable base plate for various applications. A true combination plate for various applications in the 85 kg weight class.

Designed for the compaction of granular and mixed materials with some cohesive content in confined areas such as parking lots, highway and bridge construction, next to structures, curbs, and abutments. This computer designed base plate has a tapered bottom and edges for high speed and excellent manoeuvrability.



Features and benefits

- Straight, centre-mounted guide handle offers superior manoeuvrability and can be lowered within inches of the surface to operate plate under obstacles and form work.
- Many lifting points and front lift cage offer easier loading and unloading for operator convenience.
- Compact design, easy to use, cast bottom plate.
- Smooth and flexible.
- Throttle mounted on the operating handle.

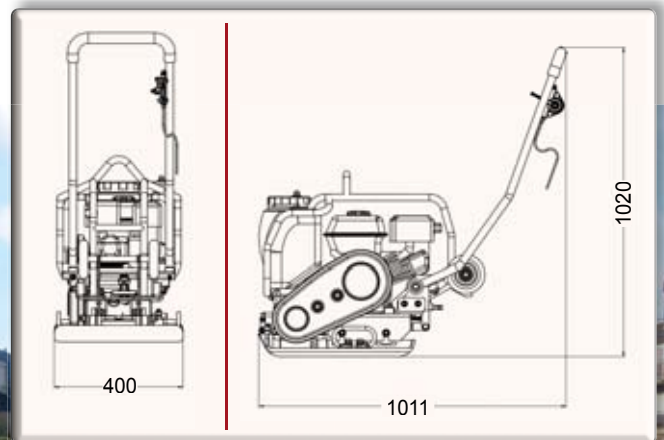

Code Model	V400COMBI V400 COMBI	V450H2 V450 COMBI
Operating mass (kg)	92	92
Centrifugal force (kN)	14	14
Plate width (mm)	450	450
Engine brand	Honda GX160	Honda GX160
Power hp (kW)	5,5 (4,1)	5,5 (4,1)
Water tank (L)	13	13
Speed (m/min)	21	21
Amplitude (mm)	0,89	0,89
Frequency (Hz)	95	95
Sound pressure level dB (A)	91	91
Vibrations* (m/s ²)	2,62	2,62

* Minimum vibration levels measured to EN500-4

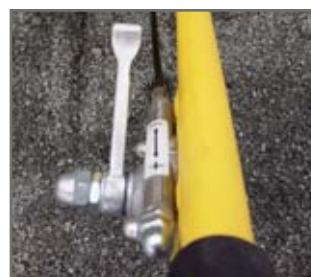

OPTION PAVING PAD	
Code	PPV-PAD400